

# 9000

*Technical Manual*



## Viscosity and temperature blind transducer (To drive one MIVI sensor)

Original version

REF.: 381/3

# IMPORTANT

## **THE OFFSET ADJUSTMENT IN THE AIR** **MUST BE THE FIRST TASK COMPLETED.**

1. **CLEAN AND DRY THE SENSOR ROD.**
2. **BE SURE THE PROCESS IS EMPTY. THE ROD MUST BE VIBRATING IN THE AIR.**
3. **INSTALL THE SENSOR ON THE PROCESS AND FIX IT WITH ITS 4 SCREWS.**
4. **POWER ON THE DEVICE, WAIT 15 MINUTES.**

The MIVI+9000 is a complete digital system that can only communicate with other devices through its serial RS-485 port. Hence, to make the zero adjustment in the air, only a digital transmission through this port can be applied, it must be installed with its 9510 or 9710 accessory device, the zero adjustment in the air should be done on the 9510/9710 device (see 9510/9710 technical manual delivered with the unit).



# TABLE OF CONTENT

|  |           |
|--|-----------|
| <b>1. TRANSDUCER PRINCIPLE .....</b>                 | <b>4</b>  |
| <b>2. TRANSDUCER TECHNICAL CHARACTERISTICS .....</b> | <b>5</b>  |
| 2.1    DIN-rail mounting IP20 enclosure .....        | 5         |
| 2.1.1    Mechanical characteristics.....             | 5         |
| 2.1.2    Safety considerations.....                  | 5         |
| 2.1.3    System connection.....                      | 6         |
| 2.2    IP66 Enclosure .....                          | 7         |
| 2.2.1    Mechanical characteristics.....             | 7         |
| 2.2.2    Safety considerations.....                  | 7         |
| 2.2.3    System connection.....                      | 8         |
| 2.3    ATEX Enclosure.....                           | 9         |
| 2.3.1    Mechanical characteristics.....             | 9         |
| 2.3.2    Safety considerations.....                  | 9         |
| 2.3.3    System connection.....                      | 9         |
| <b>3. ACCESSORY DEVICES .....</b>                    | <b>11</b> |
| 3.1    9510 .....                                    | 11        |
| 3.2    9710 .....                                    | 12        |

# 1. Transducer principle

The measuring chain is composed of three inseparable elements: the sensor, its cable and the 9000 transducer that controls it. The sensor cannot be used with another transducer or another cable type or length because they are all a part of the resonant loop so they are matched together as one vibrating system. The MIVI+9000 is specially designed to be used with Sofraser HMI/PLC accessories (see chapter 3).

The active part of the sensor is composed of a vibrating rod held in oscillation at resonance frequency by driving magnets. When the rod is immersed into a viscous material, the amplitude of the vibration is dampened. The vibration amplitude varies according to the product viscosity where the rod is immersed.

The sensor receiving coil detects the response and the signal is converted to a viscosity value through the electronic device. The factory calibration is performed with standard oils.

The transducer acquires the coils' amplitudes and frequency and generates various signals. These signals represent the properties being measured. It is also in charge of powering the whole system. It gives viscosity and temperature information through the serial communication.

## 2. Transducer technical characteristics

### 2.1 DIN-rail mounting IP20 enclosure

#### 2.1.1 Mechanical characteristics

Hereunder are the different views of the electronics.

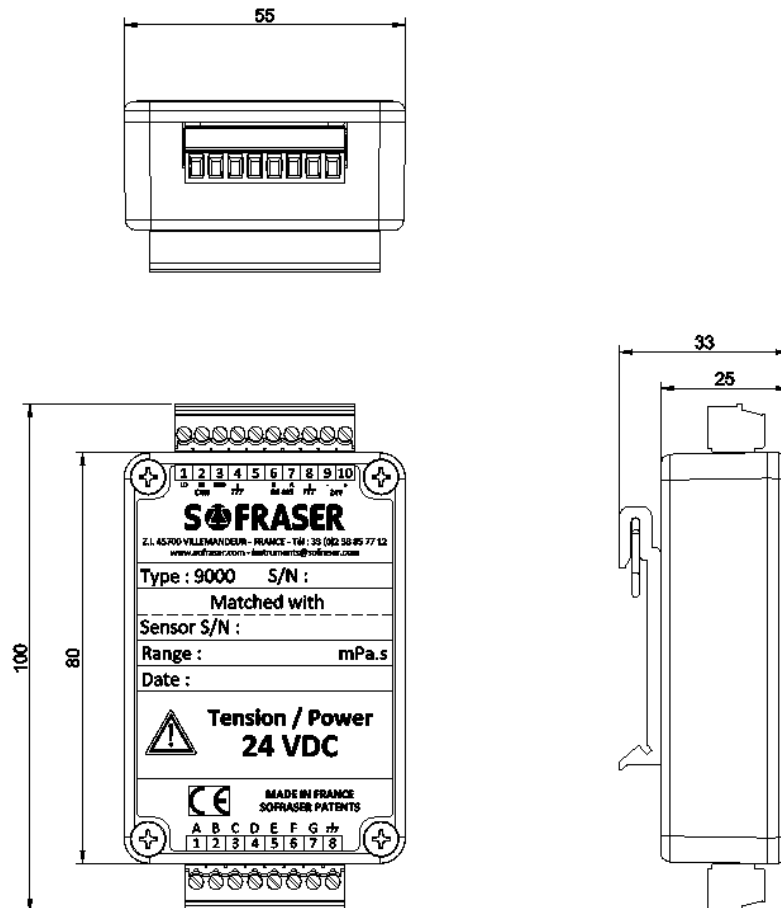

The processor must be connected to a stabilized and filtered **24 VDC** ( $\pm 2.4$  VDC) power supply. The polarity of the power supply is highly important, in order to avoid any damage on the electronic board.

The operating temperature for this electronic device should be constant, the maximum is 50°C.

The electronic device delivers the viscosity and temperature information to the selected HMI through the serial RS-485 communication port.

#### 2.1.2 Safety considerations

- Ⓢ Do not touch wires while the processor is ON.
- Ⓢ Do not connect either the “Neutral” or “Line” signal of the 110/220VAC to the device’s 0V pin.
- Ⓢ In the event of voltage fluctuations or non-conformity to voltage power supply specifications, connect the device to a filtered and stabilized power supply.
- Ⓢ Double-check all wiring before turning on the power supply.
- Ⓢ Install at maximum distance from high-voltage cables and power equipment.

- Ⓢ To maximize the system performances, avoid electromagnetic interferences by mounting the processor on a metal panel and earthing the power supply.

### 2.1.3 System connection

Only the link between the sensor and the terminal block has to be operated by the user according to the following description.

|   |   |   |   |   |            |            |       |     |         |
|---|---|---|---|---|------------|------------|-------|-----|---------|
| 1 | 2 | 3 | 4 | 5 | 6          | 7          | 8     | 9   | 10      |
|   |   |   |   |   | RS 485 (B) | RS 485 (A) | Earth | 0 V | +24 VDC |

|            |            |            |            |           |           |           |       |
|------------|------------|------------|------------|-----------|-----------|-----------|-------|
| Sensor (A) | Sensor (B) | Sensor (C) | Sensor (D) | Pt100 (E) | Pt100 (F) | Pt100 (G) | Earth |
| 1          | 2          | 3          | 4          | 5         | 6         | 7         | 8     |

The wires at the end of the cable have the following allocations.

| Wire | Color       | Item           | Transducer terminal block |
|------|-------------|----------------|---------------------------|
| A    | blue        | receiving coil | 1                         |
| B    | brown       |                | 2                         |
| C    | transparent | driving coil   | 3                         |
| D    | black       |                | 4                         |
| E    | red         | Pt100          | 5                         |
| F    | yellow      |                | 6                         |
| G    | green       |                | 7                         |
| N/A  | metal       | Earth          | 8                         |

## 2.2 IP66 Enclosure

### 2.2.1 Mechanical characteristics

Hereunder are the different views of the IP66 enclosure.

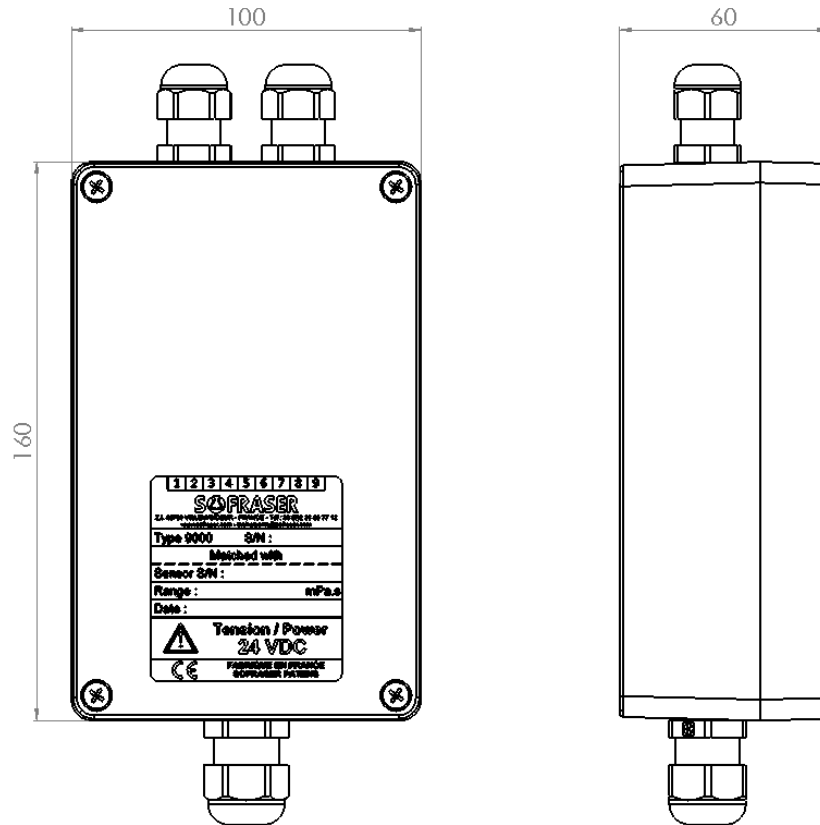

The processor must be connected to a stabilized and filtered **24 VDC** ( $\pm 2.4$  VDC), 1 A power supply. The polarity of the power supply is highly important, in order to avoid any damage on the electronic board.

The transducer box is IP66 can be mounted on a panel or a plate through 4 screws.

The operating temperature for this electronic device should be constant, the maximum is 50°C.

This enclosure is equipped with 3 cable glands.

The electronic device delivers the viscosity and temperature information to the selected HMI through the serial RS-485 communication port.

### 2.2.2 Safety considerations

- ⓘ Do not touch wires while the processor is ON.
- ⓘ Do not connect either the “Neutral” or “Line” signal of the 110/220VAC to the device’s 0V pin.
- ⓘ In the event of voltage fluctuations or non-conformity to voltage power supply specifications, connect the device to a filtered and stabilized power supply.
- ⓘ Double-check all wiring before turning on the power supply.
- ⓘ Install at maximum distance from high-voltage cables and power equipment.
- ⓘ To maximize the system performances, avoid electromagnetic interferences by mounting the processor on a metal panel and earthing the power supply.



### 2.2.3 System connection

All the connections to the electronic device are made on the terminal block located inside the blue enclosure.

**All the wiring between the electronic board and the terminal block are not to be touched.**

Only the link between the sensor and the terminal block has to be operated by the user according to the following description.

In case a cable gland is not used, this one has to be sealed with a cap.

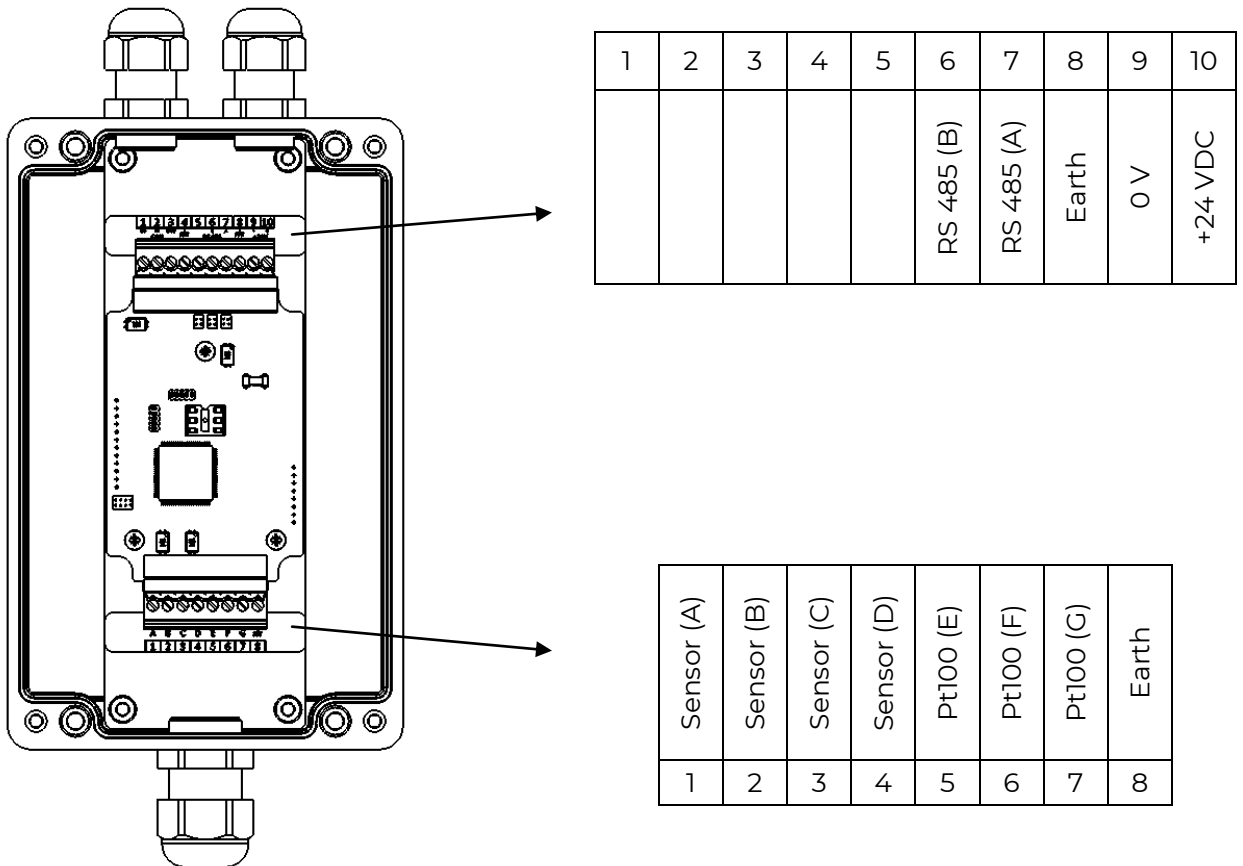

The wires at the end of the cable have the following allocations.

| Wire | Color             | Item           | Transducer terminal block |
|------|-------------------|----------------|---------------------------|
| A    | blue              | receiving coil | 1                         |
| B    | brown             |                | 2                         |
| C    | transparent black | driving coil   | 3                         |
| D    |                   |                | 4                         |
| E    | red               | Pt100          | 5                         |
| F    | yellow            |                | 6                         |
| G    | green             |                | 7                         |
| N/A  | metal             | Earth          | 8                         |

## 2.3 ATEX Enclosure

### 2.3.1 Mechanical characteristics

Hereunder are the different views of the ATEX enclosure.

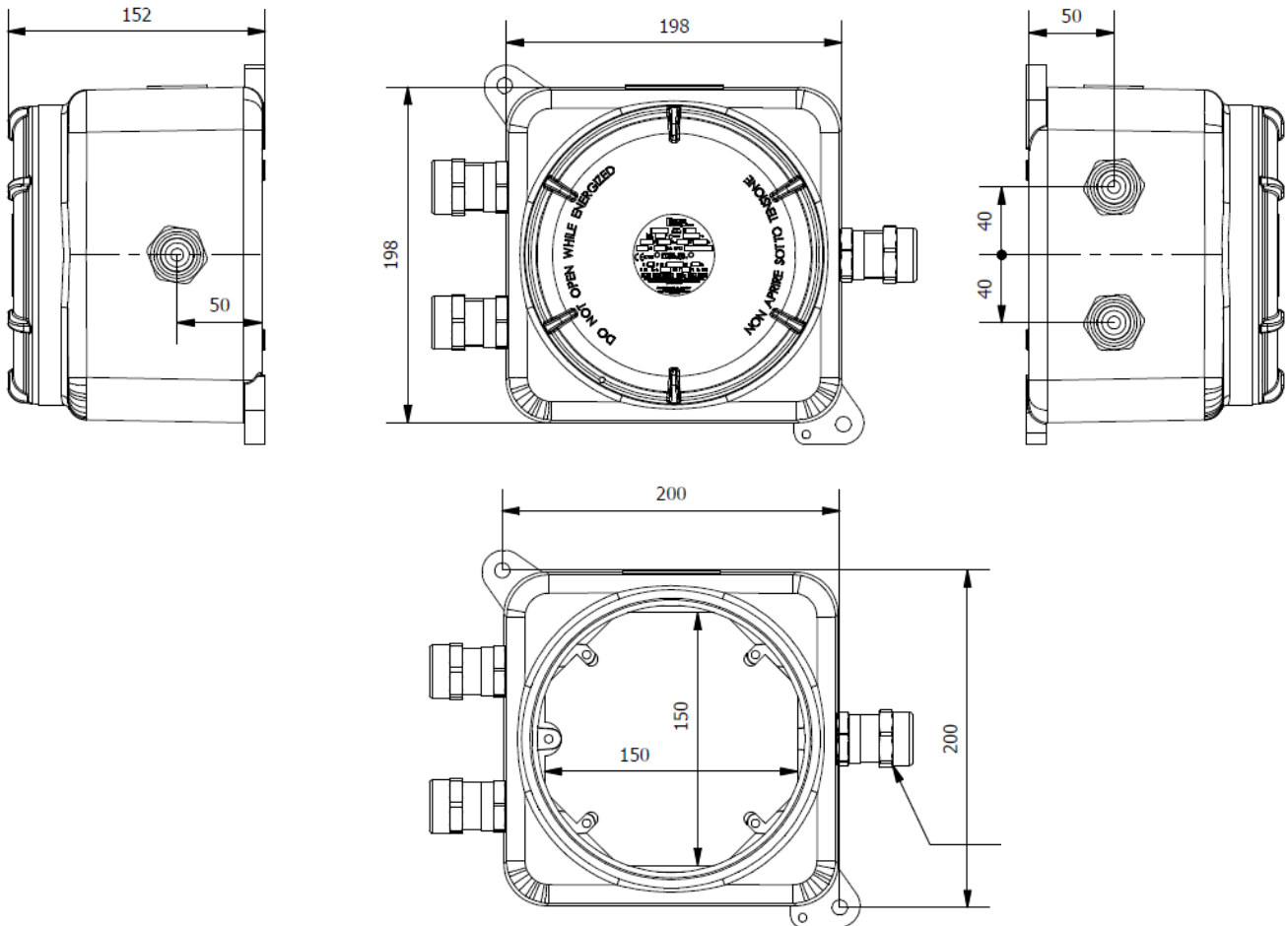

### 2.3.2 Safety considerations

- ⚠ Do not touch wires while the processor is ON.
- ⚠ Do not connect either the "Neutral" or "Line" signal of the 110/220VAC to the device's 0V pin.
- ⚠ In the event of voltage fluctuations or non-conformity to voltage power supply specifications, connect the device to a filtered and stabilized power supply.
- ⚠ Double-check all wiring before turning on the power supply.
- ⚠ Install at maximum distance from high-voltage cables and power equipment.
- ⚠ To maximize the system performances, avoid electromagnetic interferences by mounting the processor on a metal panel and earthing the power supply.

### 2.3.3 System connection

When installed in an ATEX enclosure, the 9000 transducer is in its standard IP20 enclosure. The connections are therefore identical to the ones described in 2.1.3.

|   |   |   |   |   |   |   |   |   |    |
|---|---|---|---|---|---|---|---|---|----|
| 1 | 2 | 3 | 4 | 5 | 6 | 7 | 8 | 9 | 10 |
|---|---|---|---|---|---|---|---|---|----|

|  |  |  |  |  |            |            |       |     |         |
|--|--|--|--|--|------------|------------|-------|-----|---------|
|  |  |  |  |  | RS 485 (B) | RS 485 (A) | Earth | 0 V | +24 VDC |
|--|--|--|--|--|------------|------------|-------|-----|---------|

|   |            |            |            |            |           |           |           |       |
|---|------------|------------|------------|------------|-----------|-----------|-----------|-------|
|   | Sensor (A) | Sensor (B) | Sensor (C) | Sensor (D) | Pt100 (E) | Pt100 (F) | Pt100 (G) | Earth |
| 1 | 2          | 3          | 4          | 5          | 6         | 7         | 8         |       |

The wires at the end of the cable have the following allocations.

| Wire | Color       | Item           | Transducer terminal block |
|------|-------------|----------------|---------------------------|
| A    | blue        | receiving coil | 1                         |
| B    | brown       |                | 2                         |
| C    | transparent | driving coil   | 3                         |
| D    | black       |                | 4                         |
| E    | red         | Pt100          | 5                         |
| F    | yellow      |                | 6                         |
| G    | green       |                | 7                         |
| N/A  | metal       | Earth          | 8                         |

### 3. Accessory devices

The 9510 and 9710 devices have been designed as accessories to the MIVI+9000 sensor.

#### 3.1 9510

The 9510 is an accessory processor that is to be connected to the 9000 transducer of the MIVI sensor in order to add numerous functions to the whole system.

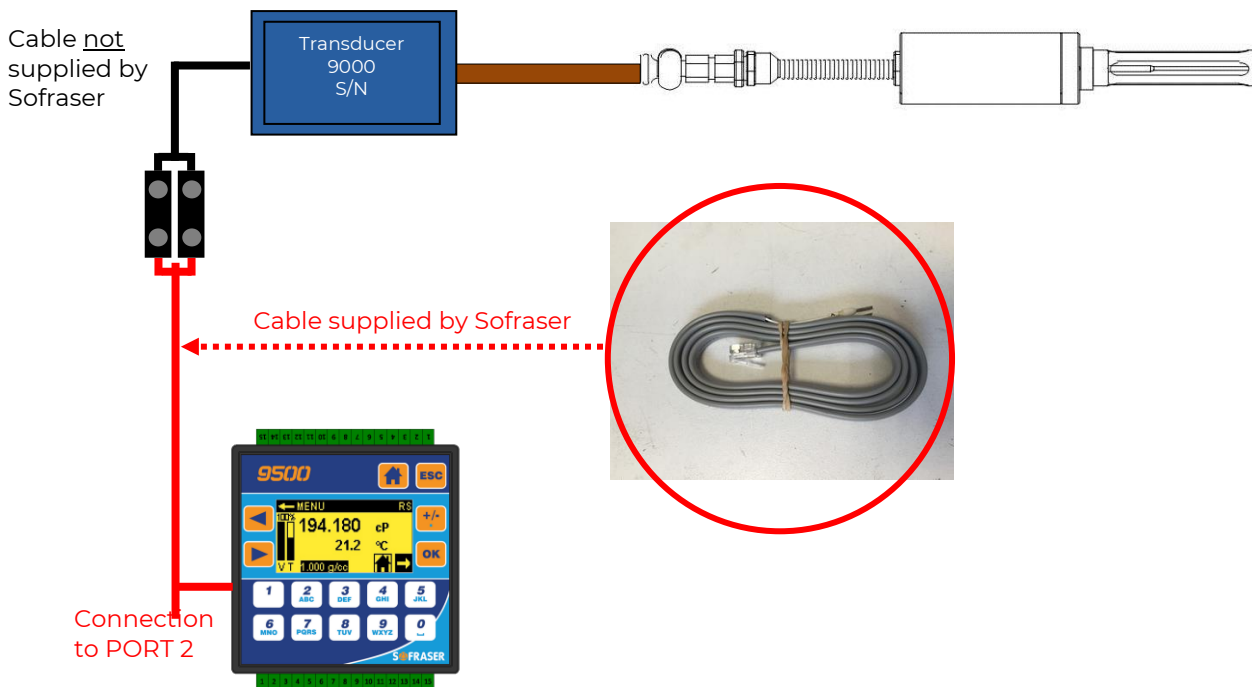

The 9510 electronic device has been designed in order to control 1 MIVI sensor. This means the MIVI's transducer 9000 and the 9510 are connected in a RS-485 serial loop as shown in the scheme just above.

See user manual ref. 390 for detailed information about the 9510 processor.

### 3.2 9710

The 9710 is an Human Machine Interface (HMI) that is to be connected to the 9000 transducer of the MIVI sensor in order to add numerous functions to the whole system.

The connection between the MIVI+9000 and the 9710 has to be done in a similar way as for the 9510 but connecting the RS-485 cable to PORT 1.

