

MAIN MIVI MOUNTING – In Tank

ON REACTOR MOUNTING
Mounting flange on reactor wall
Immersion tube on reactor wall
Immersion tube from top
Mounting on double jacket reactor

ON REACTOR MOUNTING

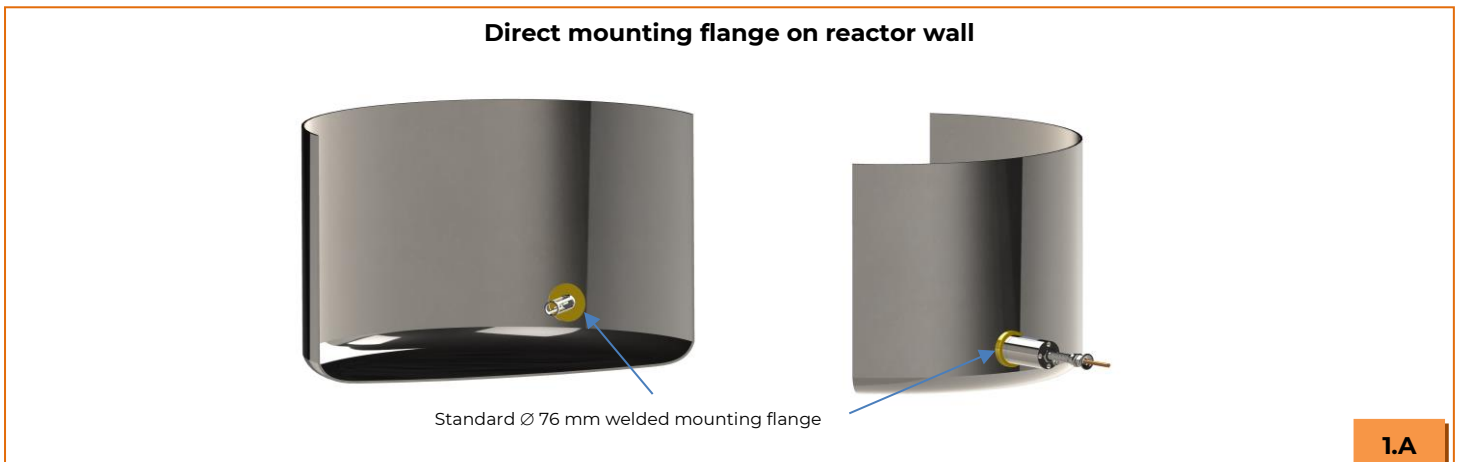

SPECIAL MOUNTING ON REACTOR

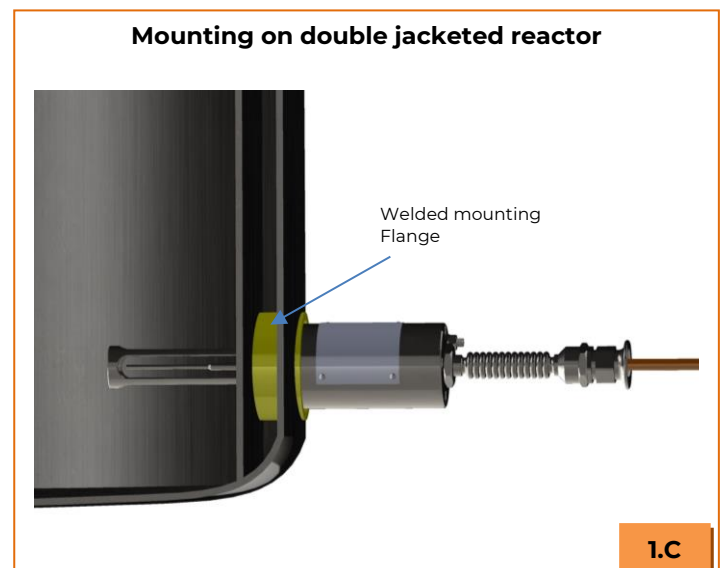
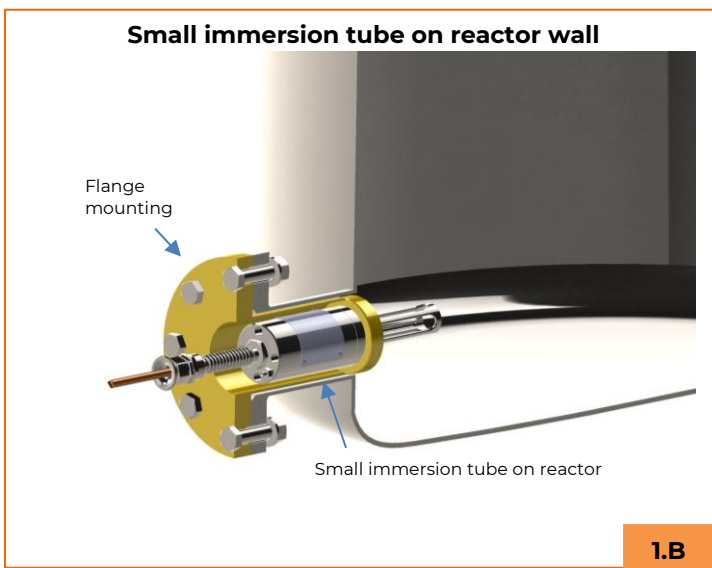

SPECIAL MOUNTING ON REACTOR

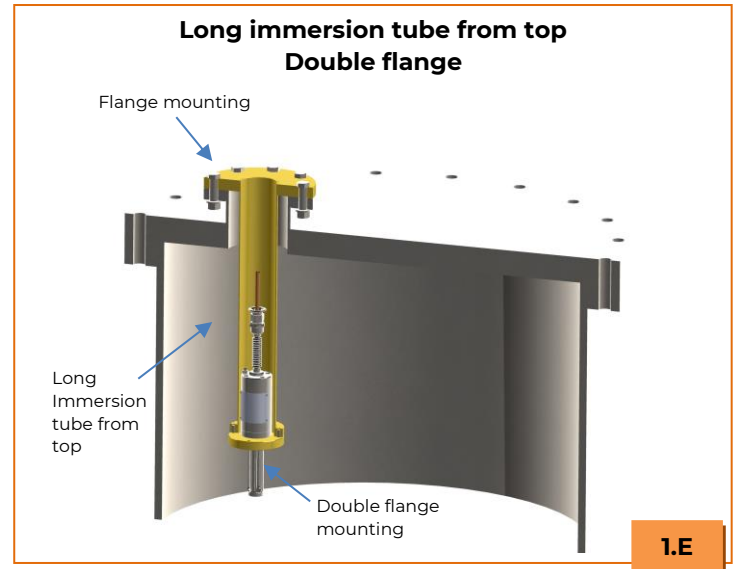
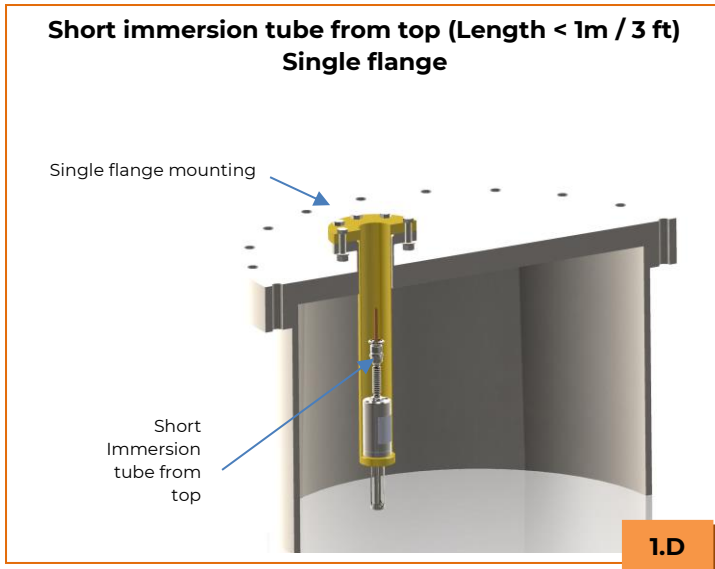

Important:

- Avoid installing the MIVI in the pathway of stirrers and other moving parts
- Do not install the MIVI in dead zones where product is not stirred and/or renewed